

Series VSMR..

- Max. vacuum level : -90kPa (-26.57 inHg)
- Max. flow rate : 85.8 NI/min (3.03 scfm)
- Supply air pressure : 3~6 bar, max 7 bar
(43.5~87psi, max 101.5psi)
- Air consumption : 20~32 NI/min (0.7~1.13 scfm)
- Supply air type : Dry compressed air
- Working temperature : -20°C ~ +80°C
- Noise level : 55~65 dBA



Main advantages

- Efficient individual and independent point-of-use vacuum.
- Extremely quick response.
- Multiple connection ports available
- Quick release system without release control valve.
- Maintains vacuum despite fluctuations and drops in air pressure.
- VMECA TWOFOLD SILENCER^{PT} assures low noise levels.
(about 30% lower than conventional silencer)

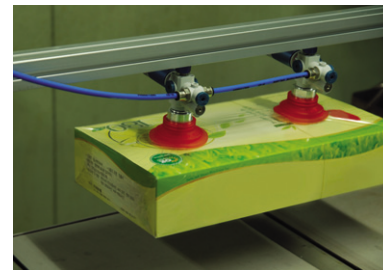

Order No.

VSMR 203 - PT8..VBF80 PU - 38M



▲ See pages 83-97

① Vacuum cartridge

- **203** - Vacuum cartridge VC203
incl. twofold silencer

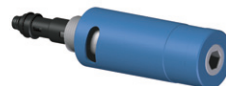

- 202 - Vacuum cartridge VC202
incl. holding plug



② Mount and mounting position

- | | | |
|--------------|---|--|
| F | - 4x screw M4 top, 5x plug G1/8" (direct mount) | |
| MT8 | - M8 16mm screw top, 4x plug G1/8" incl. mounting kit | |
| ML8 | - M8 16mm screw left, 4x plug G1/8" incl. mounting kit | |
| MR8 | - M8 16mm screw right, 4x plug G1/8" incl. mounting kit | |
| • PT8 | - M8 27mm screw top, 4x plug G1/8" incl. profile kit with jam nut | |
| PL8 | - M8 27mm screw left, 4x plug G1/8" incl. profile kit with jam nut | |
| PR8 | - M8 27mm screw right, 4x plug G1/8" incl. profile kit with jam nut | |
| PT6 | - M6 22mm screw top, 4x plug G1/8" incl. profile kit with jam nut | |
| PL6 | - M6 22mm screw left, 4x plug G1/8" incl. profile kit with jam nut | |
| PR6 | - M6 22mm screw right, 4x plug G1/8" incl. profile kit with jam nut | |



Technical Data

Model	Feed pressure (MPa)	Air consumption (NI/m)	Max. Vacuum level (-kPa)	Suction cup	Time, s/l, evacuate a volume to different vacuum level	
					-20 kPa	-60 kPa
VSMR 203.. VSM 203..	0.314	26	90	VB 30..	0.05	0.09
				VB40..	0.06	0.1
				VB50..	0.07	0.12
				VB75 (B)..	0.15	0.22
				VBF 30..	0.05	0.08
				VBF 40..	0.05	0.09
				VBF 50..	0.06	0.1
				VBF 60..	0.08	0.12
				VBF 80..	0.14	0.18
				VBF 100..	0.17	0.2
				VBL 30..	0.05	0.09
				VBL 40..	0.08	0.12
				VBL 50..	0.1	0.14
				VF 30..	0.04	0.07
				VF 40..	0.04	0.07
				VF 50..	0.05	0.08
				VF 75..	0.06	0.11
				VF 90..	0.07	0.12
				VF 110..	0.11	0.17
				VFC 50..	0.05	0.09
				VFC 60..	0.06	0.11
				VFC 75..	0.08	0.13
				VFC 90..	0.11	0.18
				VFC 100..	0.13	0.2
				VOU 15X45..	0.04	0.07
				VOU 20X60..	0.05	0.08
				VOC 35X90..	0.06	0.11
				VOC 35X110..	0.07	0.13
VOC 60X140..	0.13	0.15				
VOC 60X180..	0.16	0.18				
VSMR 202.. VSM 202..	0.314	26	90	VB 30..	0.06	0.09
				VB 40..	0.07	0.1
				VB 50..	0.08	0.13
				VB 75 (B)..	0.17	0.25
				VBF 30..	0.05	0.08
				VBF 40..	0.05	0.09
				VBF 50..	0.06	0.11
				VBF 60..	0.08	0.13
				VBF 80..	0.16	0.21
				VBF 100..	0.2	0.26
				VBL 30..	0.06	0.1
				VBL 40..	0.08	0.13
				VBL 50..	0.1	0.16
				VF 30..	0.04	0.07
				VF 40..	0.04	0.08
				VF 50..	0.05	0.09
				VF 75..	0.06	0.11
				VF 90..	0.07	0.12
				VF 110..	0.12	0.19
				VFC 50..	0.05	0.09
				VFC 60..	0.06	0.12
				VFC 75..	0.09	0.14
				VFC 90..	0.11	0.2
				VFC 100..	0.14	0.21
				VOU 15X45..	0.04	0.07
				VOU 20X60..	0.05	0.08
				VOC 35X90..	0.06	0.12
				VOC 35X110..	0.07	0.14
VOC 60X140..	0.15	0.2				
VOC 60X180..	0.17	0.22				

VACUUM SPEEDER

Dimension

▼ VSMR 203..

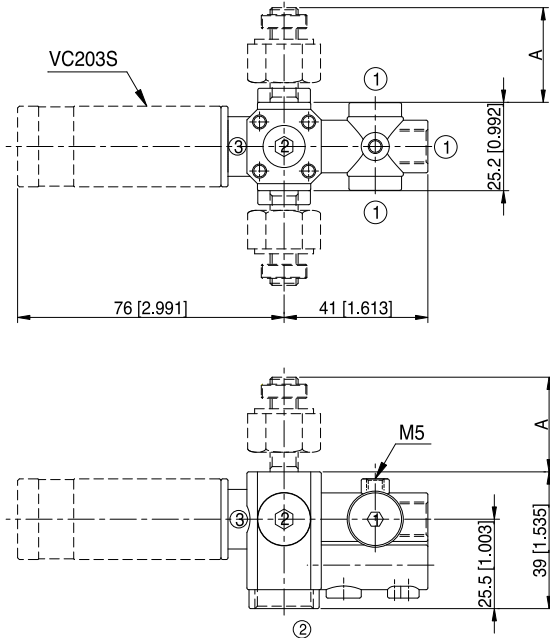

▼ VSM 203..

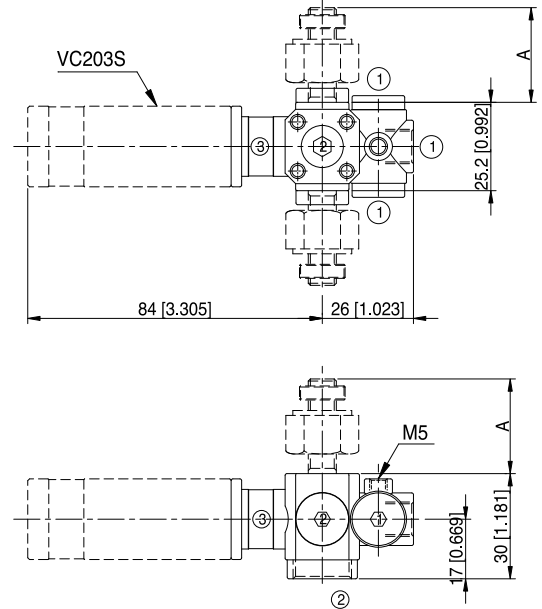

Measure unit : mm [inch]

Mounting	A	
M□8	16	1. Compressed air : 3 x G1/8"
P□8	27	2. Vacuum : 1 x G3/8" and 3 x G1/8"
P□6	22	3. Exhaust

▼ VSMR 202..

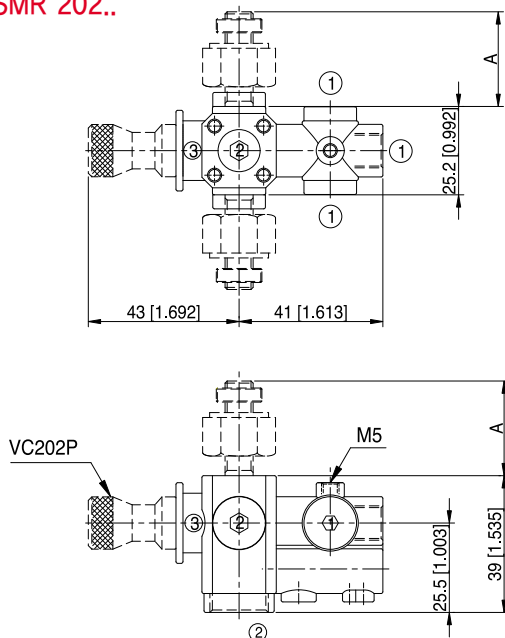

▼ VSM 202..

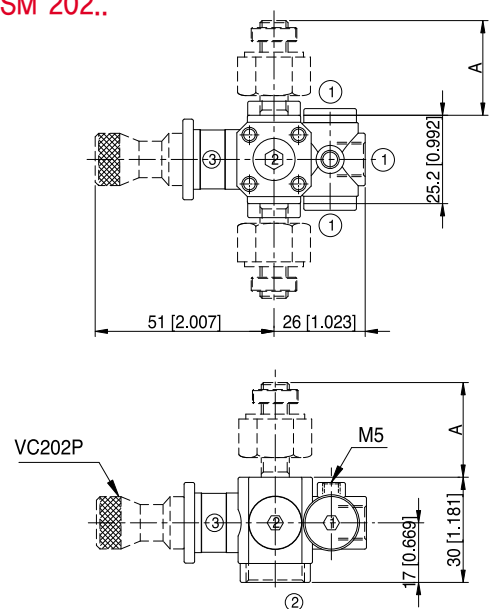

Measure unit : mm [inch]

Mounting	A	
M□8	16	1. Compressed air : 3 x G1/8"
P□8	27	2. Vacuum : 1 x G3/8" and 3 x G1/8"
P□6	22	3. Exhaust

Refer to page 83~97 about dimension of suction cups.

How to select Suction cup

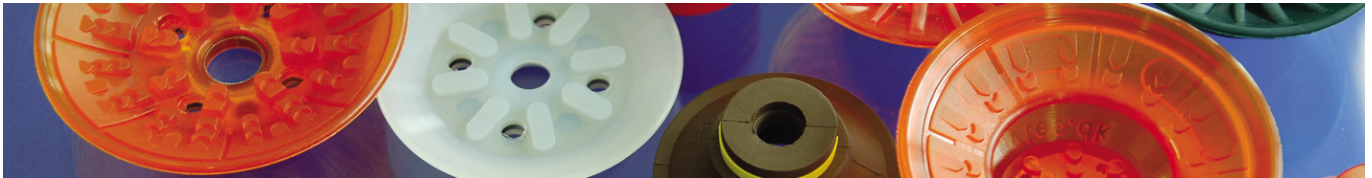

Suction cup	Shape			Requirements							
	Flat	Slightly surface	Concave surface	Smooth surface	Uneven surface	Varying surface levels	Thin flexible materials	Good stability	Safety	Parallel lift	Opening plastic bag
VB	★★	★★★★		★★★★		★★★★	★★★★	★	★★★★	★	★★
VPF	★★★★	★★★★	★	★★★★		★★★★	★★★★	★★★★	★★★★	★★★★	
VBL	★★	★★★★		★★★★		★★★★	★★★★		★★		
VF	★★★★			★★★★				★★★★	★★★★	★★★★	
VFC	★★★★	★★★★		★★★★	★			★★★★	★★★★	★★★★	★
VOU	★★★★	★★	★★	★★★★				★★	★★	★	
VOC	★★★★	★★★★		★★★★		★		★★★★	★★★★	★★★★	

★★★★ Excellent ★★ Very good ★ good

Slightly curved surface
VB model

▶ See page 84

Transferring to parallel
VF, VFC model

▶ See page 90, 92

Thin flexible material
VBL model

▶ See page 88

Long convex or flat
VOU model

▶ See page 94

Sheet metal
VPF model

▶ See page 86

Long flat
VOC model

▶ See page 96

Material and characteristic of suction cup

Material	Durability	Temperature	Oil Resistance	Weather & Ozone
N - NBR	Excellent	-20°C ~ +110°C	Excellent	Very Good
S - Silicon, WS-White Silicon	Good	-70°C ~ +200°C	Unsuitable	Excellent
HS-High Temp. Silicon	Good	-70°C ~ +280°C	Unsuitable	Excellent
C.S - Conducive(Special mat'l)	Excellent	-45°C ~ +90°C	Excellent	Very Good
U - Urethane	Excellent	0°C ~ +100°C	Excellent	Excellent
A - Mark free	Excellent	-10°C ~ +100°C	Excellent	Very Good
PU - Poly Unethane	Excellent	0°C ~ +60°C	Excellent	Excellent
E - EPDM	Very Good	0°C ~ +150°C	Unsuitable	Excellent