



ISO 9001 CERTIFIED



0575



II 1Dc 90°C / II 2 GD c 100°C



# VACUUM CONVEYOR SYSTEM





# DET NORSKE VERITAS

## EC-TYPE EXAMINATION CERTIFICATE

- [2] **EQUIPMENT OR PROTECTIVE SYSTEM INTENDED FOR USE IN POTENTIALLY EXPLOSIVE ATMOSPHERES DIRECTIVE 94/9/EC**
- [3] EC-Type Examination Certificate Number: **DNV 13 ATEX 2880X**
- [4] Equipment or Protective System: **VACUUM CONVEYOR**
- [5] Applicant – Manufacturer or Authorized representative: **KOREA PNEUMATIC SYSTEM CO., LTD.**
- [6] Address: **#153-817 501-5, DOKSAN 1-DONG, GEUMCHEON – GU, SEOUL, KOREA**
- [7] This equipment or protective system and any acceptable variation thereto is specified in the schedule to this certificate and the documents therein referred to.
- [8] DNV, notified body number 0575 in accordance with Article 9 of Council Directive 94/9/EC of 23 March 1994, certifies that this equipment or protective system has been found to comply with the Essential Health and Safety requirements relating to the design and construction of equipment and protective systems intended for use in potentially explosive atmospheres given in Annex II to the Directive.
- The examination and test results are recorded in confidential reports listed in section 14.
- [9] Compliance with the Essential Health and Safety Requirements has been assured by compliance with:  
**EN 13463-1:2009 & EN 13463-5:2011**
- [10] If the sign “X” is placed after the certificate number, it indicates that the equipment or protective system is subject to special conditions for safe use specified in the schedule to this certificate.
- [11] This EC-TYPE EXAMINATION CERTIFICATE relates only to the design and construction of the specified equipment or protected system. If applicable, further requirements of this Directive apply to the manufacturer and supply of this equipment or protective system.
- [12] The marking of the equipment or protective system shall include the following:

 **II 1 D e 90 °C / II 2 G D e 100 °C**

Høvik, 2013-09-17  
for Det Norske Veritas AS

  
Asle Kaastad  
*Certification Manager*



Notice: This Certificate is subject to terms and conditions overleaf. Any significant change in design or construction may render this Certificate invalid. The digitally signed and electronically distributed document is the original and valid certificate. Ref.: [www.dnv.com/digitalsignatures](http://www.dnv.com/digitalsignatures)

If any person suffers loss or damage which is proved to have been caused by any negligent act or omission of Det Norske Veritas, then Det Norske Veritas shall pay compensation to such person for his proved direct loss or damage. However, the compensation shall not exceed an amount equal to ten times the fee charged for the service in question, provided that the maximum compensation shall never exceed USD 300,000. In this provision "Det Norske Veritas" shall mean the Foundation Det Norske Veritas as well as all its subsidiaries, directors, officers, employees, agents and any other acting on behalf of Det Norske Veritas.



[13]

## Schedule

[14] **EC-TYPE EXAMINATION CERTIFICATE No.:** DNV 13 ATEX 2880X

### Certificate History

Revision	Description	Report no.	Issue date
-	Original certificate	2013-9263	2013-09-17

[15] **Description of Equipment or Protective System**

The vacuum conveyor systems of the model series V-MECA, with the type designations VTC100, VTC200, VTC400, VTC600, VTC800, VTC1000 and VTC1200 serve the continuous transport of bulk goods in vacuum stream. The systems consist of a vacuum pump, conveyor module, filter system, air shock tank, hopper cone, actuator and a pneumatic control system. The type designations differ only in diameter and in their modular structure.

### Technical Data

Type variant	Max. Capacity (T/h)	Air Consumption (l/min)	Dimension (Φ mm)
VTC100	0,6	280	320 x 690
VTC200	1,0	560	320 x 690
VTC400	2,1	1120	320 x 790
VTC600	3,1	1680	620 x 1046
VTC800	4,2	2240	620 x 1046
VTC1000	5,2	2800	620 x 1413
VTC1200	6,0	3360	620 x 1413

[16] **Project No.:** PRJC-270363-2010-PRC-KOR

### Descriptive Documents

Number	Title	Rev.	Date
KPS-VTC-100400SA-000	GENERAL ASSEMBLY-1	1.0	2013.04.20
KPS-VTC-6001200SA-000	GENERAL ASSEMBLY-2	1.0	2013.04.20
KPS-VTC-100400PSA-001	VTC100-400 PART ASSY-1	1.0	2013.04.15
KPS-VTC-100400PSA-002	VTC100-400 PART ASSY-2-1	1.0	2013.04.15
KPS-VTC-100400PSA-003	VTC100-400 PART ASSY-2-2	1.0	2013.04.15
KPS-VTC-100400PSA-004	VTC100-400 PART ASSY-3	1.0	2013.04.15
KPS-VTC-6001200PSA-001	VTC600-1200 PART ASSY-1	1.0	2013.04.27
KPS-VTC-6001200PSA-002	VTC600-1200 PART ASSY-2	1.0	2013.04.27
KPS-VTC-6001200PSA-003	VTC600-1200 PART ASSY-3	1.0	2013.04.27
KPS-VTC-112WP-000	WARNING PANEL VTC100-1200	1.0	2013.03.29
KPS-VTC-112NP-000	NAME PANEL VTC100-1200	1.0	2013.03.29

If any person suffers loss or damage which is proved to have been caused by any negligent act or omission of Det Norske Veritas, then Det Norske Veritas shall pay compensation to each person for his proved direct loss or damage. However, the compensation shall not exceed an amount equal to ten times the fee charged for the service in question, provided that the maximum compensation shall never exceed USD 300,000. In this provision 'Det Norske Veritas' shall mean the Foundation Det Norske Veritas as well as all its subsidiaries, directors, officers, employees, agents and any other acting on behalf of Det Norske Veritas.



**EC-TYPE EXAMINATION CERTIFICATE No.:** DNV 13 ATEX 2880X

**[17] Special Conditions for Safe Use**

It may only be conveyed bulk materials, the minimum ignition energy > 3 mJ is. There must be no flammable gases and vapours may be present in the bulk materials or be transported together. The maximum fuel temperature of the bulk material must not exceed 60°C. The delivery of the absorbed bulk material must not be placed directly in hazardous areas of zone 0 and 1.

The aspirated material amount may not exceed the mass of 10 kg each intake stroke.

**[18] Essential Health and Safety Requirements**

See part 9 of this certificate

END OF CERTIFICATE

If any person suffers loss or damage which is proved to have been caused by any negligent act or omission of Det Norske Veritas, then Det Norske Veritas shall pay compensation to such person for his proved direct loss or damage. However, the compensation shall not exceed an amount equal to ten times the fee charged for the service in question, provided that the maximum compensation shall never exceed USD 300,000. In this provision 'Det Norske Veritas' shall mean the Foundation Det Norske Veritas as well as all its subsidiaries, directors, officers, employees, agents and any other acting on behalf of Det Norske Veritas.



## Why!! We are VMECA Vacuum conveyor system?

- ▶ Minimal Maintenance
- ▶ Low Noise Level
- ▶ Automatic Filter Cleaning System
- ▶ Simple to Installation
- ▶ Compact Size
- ▶ Easy To Clean
- ▶ Dustless Conveying
- ▶ Acid-Proof
- ▶ Polished Stainless Steel
- ▶ Easy to Maintenance
- ▶ Transports Large Amount
- ▶ Atmospheres Explosibles

Approval(ATEX) 



ISO 9001 CERTIFIED



0575



II 1Dc 90°C / II 2 GD c 100°C

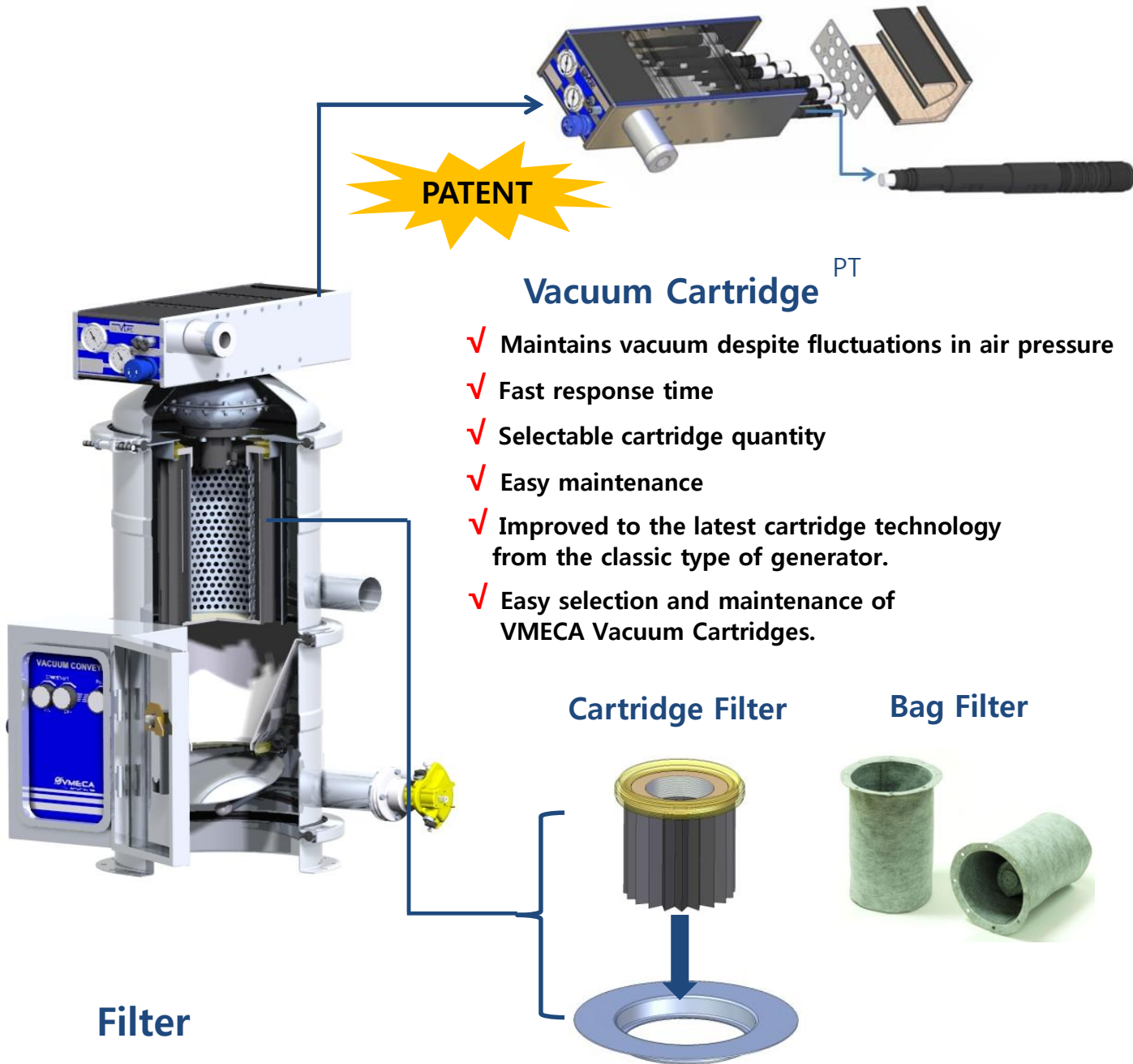

**PATENT**

## Vacuum Cartridge <sup>PT</sup>

- ✓ Maintains vacuum despite fluctuations in air pressure
- ✓ Fast response time
- ✓ Selectable cartridge quantity
- ✓ Easy maintenance
- ✓ Improved to the latest cartridge technology from the classic type of generator.
- ✓ Easy selection and maintenance of VMECA Vacuum Cartridges.

## Cartridge Filter

## Bag Filter

## Filter

- ✓ Easy replacement
- ✓ Pleated media filter
- ✓ Large filter surface area due to a pleated media filter
- ✓ Antistatic filter
- ✓ Food quality
- ✓ Electrically Conductive Polyester with PTFE membrane(cartridge filter)
- ✓ TFE coated antistatic Felt of polyester / Carbon fibers
- ✓ Washable 2 to 4 times in 40°C ( bag filter)

# Vacuum Conveyor Principle



The Vacuum Conveyor utilizes the vacuum to pick up the material for transfer.

This process is called a difference in pressure. This is where atmospheric air and the different air pressure tries to equalize itself which in turn creates suction.

The same concept is used here when the air within the pipeline is evacuated creating a negative pressure (difference in pressure). This negative pressure has the strength to pull the solid particles through the pipeline and into the Vacuum Conveyor.

The below pictures are the order of which the materials are transferred.

The materials are poured into a tank which transfers through the pipeline mixing with the outside air and material, then the material enters the Vacuum Conveyor module, and the incoming negative pressure air is cleaned as it enters through the vacuum filter. The clean air enters the Vacuum Pump which is exhausted out through the exhaust port. All of these functions are controlled by the Control Box.

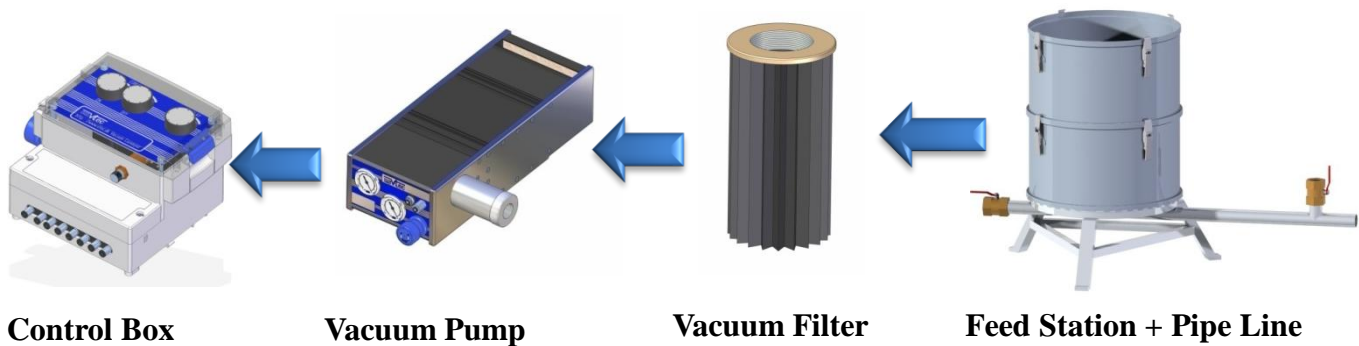

Control Box

Vacuum Pump

Vacuum Filter

Feed Station + Pipe Line

# The principle of VMECA Conveyor.

1. (D) Hopper Door closes
2. (A) Vacuum Pump starts
3. (H) Shock Tank air energizes
4. Material transfers
5. (A) Vacuum Pump stops
6. (H) Shock Tank discharges
7. (D) Hopper Door opens – Releases Product

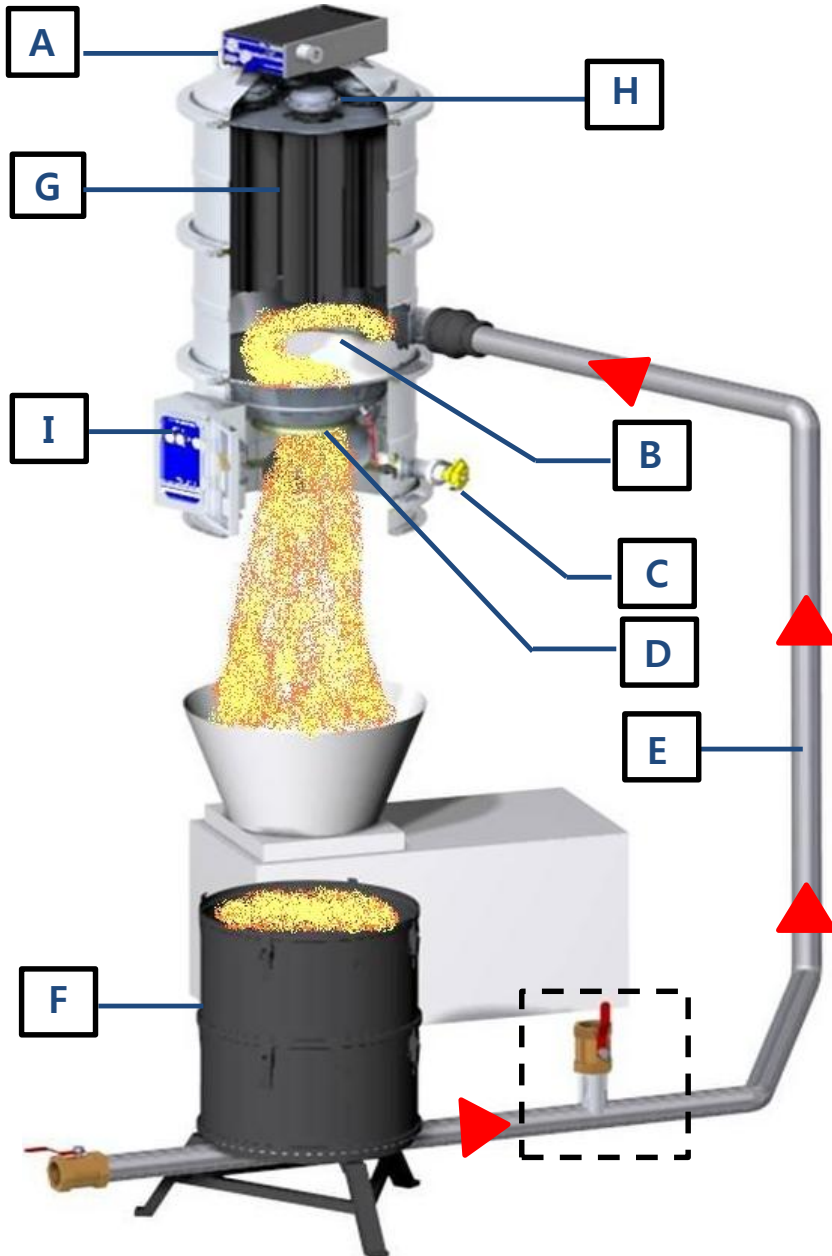

- A. Vacuum Pump
- B. Hopper Cone
- C. Actuator
- D. Hopper Door
- E. Pipeline
- F. Feed Station
- G. Filter
- H. Air Shock Tank
- I. Control Box



Manual injection valve  
(Hand valve)



Automatic injection valve  
(by pneumatic timer)



## FLUIDIZATION

Fluidization is necessary for materials that has a poor flowing capacity. The Fluidization works by shooting air into a hopper cone which has small porous openings(similar to a vacuum filter). This air passes through these porous openings allowing the materials inside the conveyor to fully dump.

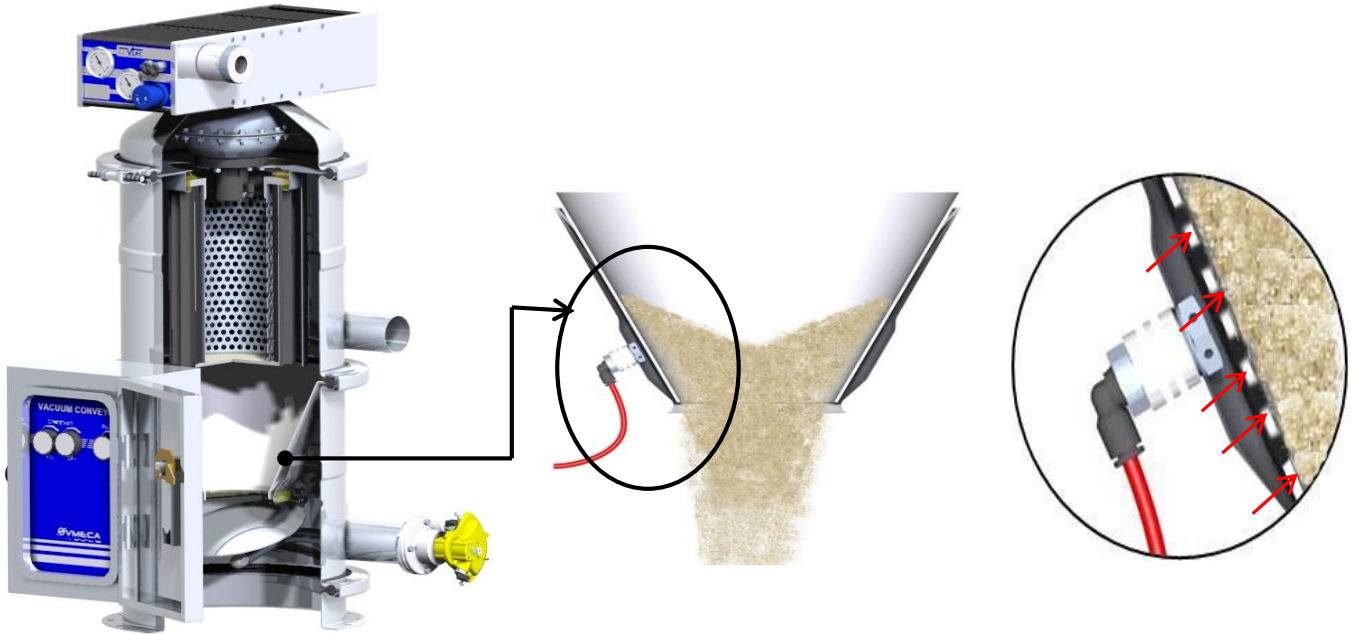

## FEED NOZZLE

The Feed Nozzle allows the operator to transport the material. It is adjustable by allowing air to flow in with the material.

This will create a smooth flow of materials giving it a good air to material ratio to prevent clogging in the pipelines.

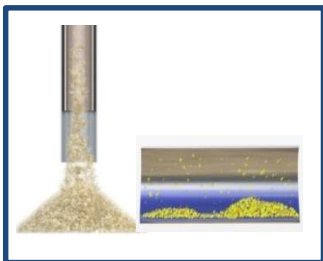

## Injection Valve

An Injection Valve is necessary when there is a 90 degree turn. The reason for this is because, if the material is transferred and drops down to the bottom, it runs into dangers of clogging the pipeline. In order to prevent this, an injection valve must be installed near the bend to allow the atmospheric air to come in and discharge the pipeline of any build ups.

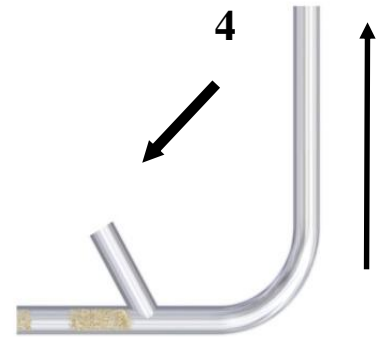
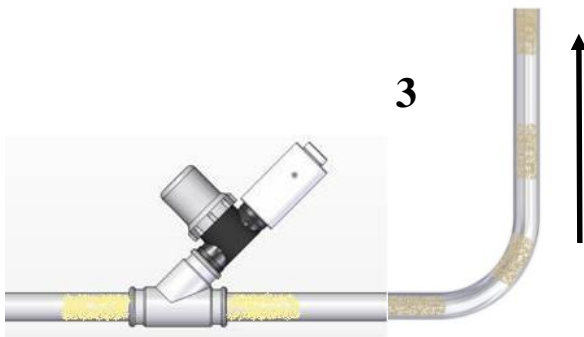
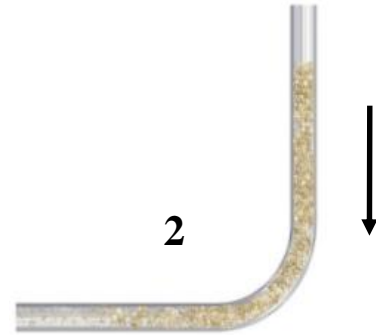
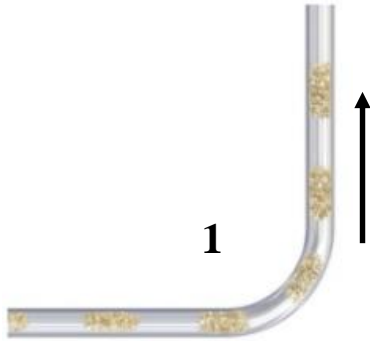

1 and 2 = Without the Injection Valve  
 3 and 4 = With the Injection Valve Installed

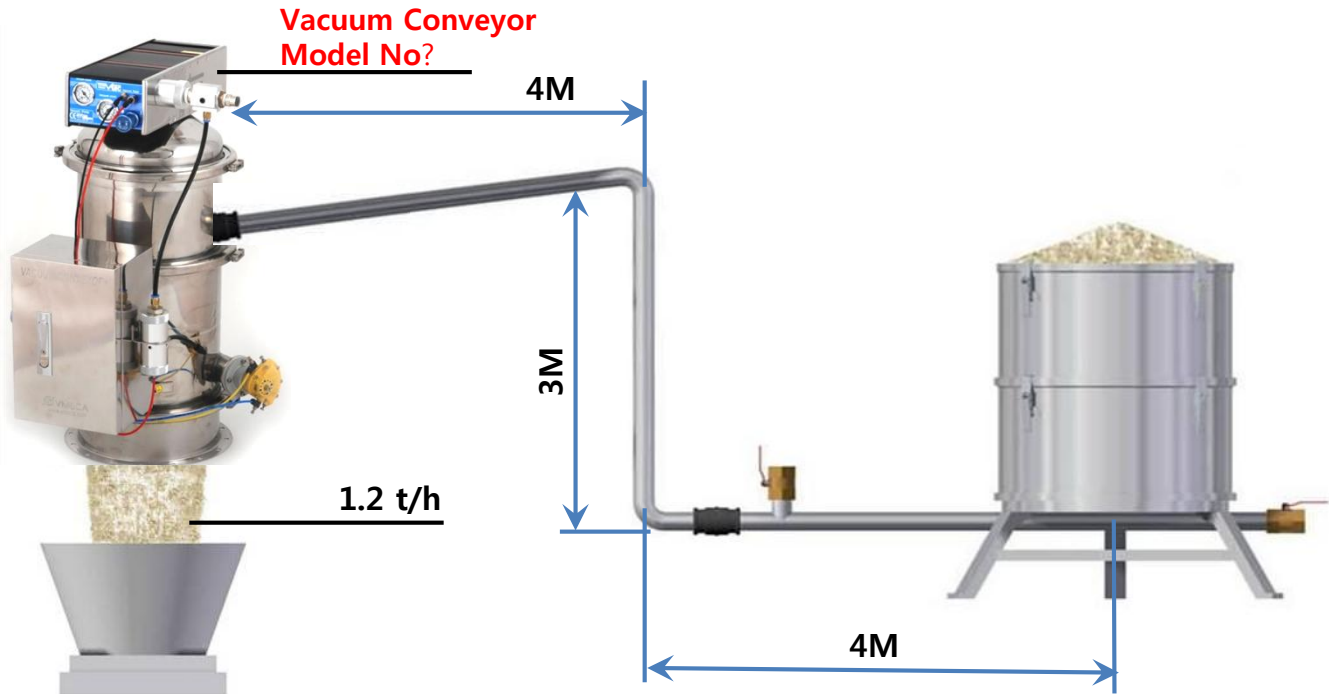

## How to select a standard conveyor?

(Example) The sugar company needs to convey 1.2 tons of granulated sugar per hour up to a mixer where the sugar is mixed with cacao powder. The mixer is located 11 meters from the Feed station.

Example)

VMECA vacuum conveyor “VTC 400” will be the best choice when the  $Pr = 10 \sim 20$  in this Example, The power requirement ( $Pr$ ) of the applications is the same as the customer’s capacity requirement. Hear the  $Pr$  figure, which is the product of capacity and conveying distance, is calculated.

- ▶ Material : granulated sugar
- ▶ Capacity :  $C = 1.2$  ton/hour
- ▶ Vertical conveying distance :  $L_v = 3$  meters
- ▶ Horizontal conveying distance :  $L = 4 + 4 = 8$  meters
- ▶ Total conveying distance :  $L = L_v + L = 3 + 8 = 11$  meters
- ▶ Characteristics of granulated sugar :
  - Bulk density  $B = 0.8$  ton/m<sup>3</sup>
  - Particle size  $P = 0.2$  mm
  - The sugar is a free flowing product.

$Pr = C \times L = 1.2 \times 11 = 13.2$  ( $Pr$  : Power requirement)

VMECA vacuum conveyor “VTC 400” will be the best choice when the  $Pr = 10 \sim 20$  in this Example,

To check)

- ▶ Bulk density,  $B = 0.8$  ton/m<sup>3</sup> (  $0.5 < B < 18$  ) OK!
- ▶ Total conveying distance,  $L = 11$ m, (  $4 < L < 30$  ) OK!
- ▶ Particle size,  $P = 0.2$ mm (  $P < 5$ mm ) OK!

Note)

The above is only a suggestion in order to facilitate the choice of conveyor. There are many applications in the market, some with higher and some with lower values than the values mentioned here. Therefore, please contact VMECA for more detailed product information.

## Series VTC 100 ..

Supply air pressure : 4 ~ 6 bar (Max 7bar)  
(58 ~ 87 psi, Max 101.5 psi)

Air consumption : 280 ~ 416 NI/min  
(9.88 ~ 14.7 scfm)

Noise level : 68 ~ 76 dBA

Steel Material : SUS304 / SUS316L

Sealing Material : Silicone

Filter Material : Electrically conductive polyester  
with PTFE membrane



### Ordering information

✓ Please contact VMECA for ATEX approval conveyor.

VTC 100 L - C2 - AC B A - M - 316L  
 ① ② ③ ④ ⑤ ⑥ ⑦ ⑧

#### ① Vacuum Pump

- 100 : Vacuum Pump with Free flow exhaust duct (standard)
- 100 CP : Vacuum Pump with Concentration exhaust port

#### ③ Filter

- B : Bag Filter – Filtering capacity (5μ)
- B2 : Bag Filter – Filtering capacity (0.5μ )
- C2 : Cartridge Filter – Polyester fleece with PTFE membrane (0.2~0.5μ )

#### ④ Control Unit

- AC –Pneumatic Control (Plastic Case)
  - Running time adjustable (0.1~30s)
  - Discharge time adjustable (0.1~30s)
  - Delay period adjustable (0.1~30s)

##### AC2- Pneumatic Control

- Running time adjustable (0.1~30s)
- Discharge time adjustable (0.1~30s)

##### AC3–Pneumatic Control (Stainless Steel Case))

- Running time adjustable (0.1~30s)
- Discharge time adjustable (0.1~30s)
- Delay period adjustable (0.1~30s)
- IP65 (Box Protection Grade)

##### EC - Electric Control

- Running time adjustable
- Discharge time adjustable
- Auto / Manual mode
- Level control available

#### ② Filtration Area

No mark - Standard

L - Extra large

#### ⑤ Blowing

B –Blowing Gear attached

No mark – Not attached

#### ⑥ Injection valve

A - Attached

No mark – Not attached

#### ⑦ Mounting Option

M –Flange Mount

No mark – Not attached

#### ⑧ Material

No mark – Standard(SUS304)

316L – SUS316L

## Specification

MODEL	Power Requirement (Pr)	Filter Surface (m <sup>2</sup> )	Max. Conveying Capacity (ton/h)	Capacity ton/h at Different Conveying distance				Rec. Material Pipe Dimension (mm)	Rec. Material Volume (l/cycle)	Weight (Kg)
				8M	13M	23M	33M			
VTC100	3 ~ 6	0.12	0.9	0.9	0.64	0.48	0.36	32 / 42	4	23
VTC100L	3 ~ 6	0.2	0.9	0.9	0.64	0.48	0.36	32 / 42	4	

Remark) 1. Above data based on actual test result of sugar which is specific gravity 0.85 in vertical 3m with 2 bends  
 2. The data can be changed according to the condition such as supply air flow, air pressure and condition of pipe line (bending) when conveyor is operating.

## Dimension

VTC100...

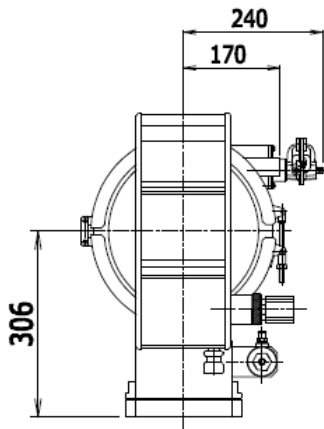

VTC100 L ...

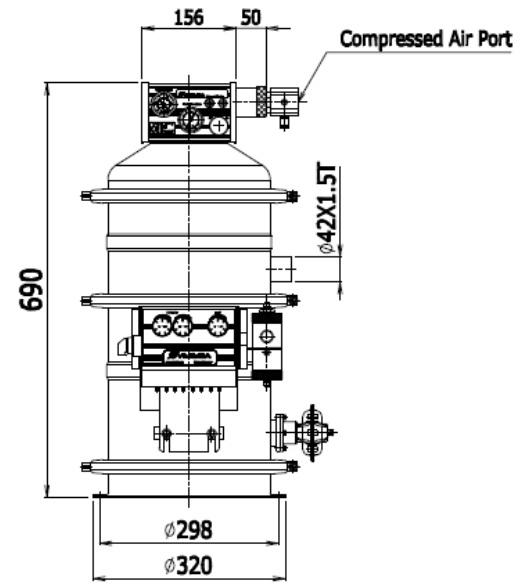
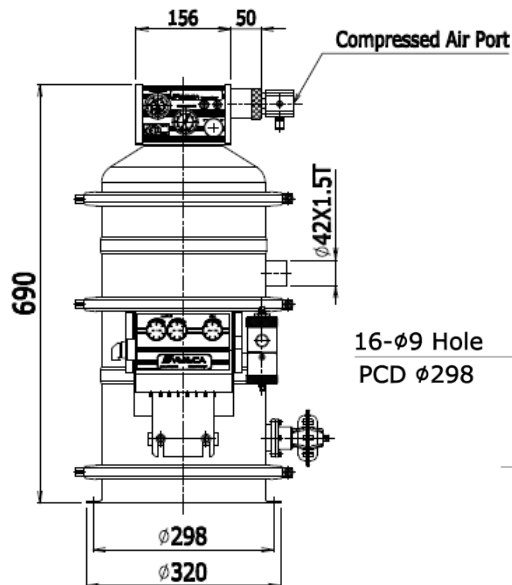
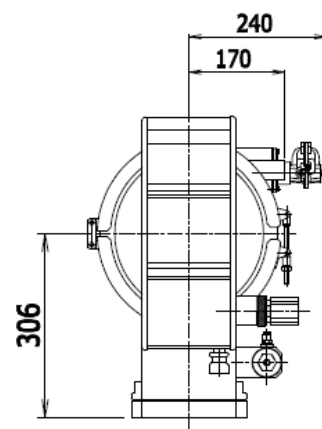

## Series VTC 200 ..

Supply air pressure : 4 ~ 6 bar (Max 7bar)  
(58 ~ 87 psi, Max 101.5 psi)

Air consumption : 560 ~ 832 NI/min  
(19.8 ~ 29.3 scfm)

Noise level : 68 ~ 76 dBA

Steel Material : SUS304 / SUS316L

Sealing Material : Silicone

Filter Material : Electrically conductive polyester  
with PTFE membrane



### Ordering information

✓ Please contact VMECA for ATEX approval conveyor.

VTC 200 L - C2 - AC B A - M - 316L  
 ① ② ③ ④ ⑤ ⑥ ⑦ ⑧

#### ① Vacuum Pump

- 200 : Vacuum Pump with Free flow exhaust duct (standard)
- 200 CP : Vacuum Pump with Concentration exhaust port

#### ③ Filter

- B : Bag Filter – Filtering capacity (5μ)
- B2 : Bag Filter – Filtering capacity (0.5μ )
- C2 : Cartridge Filter – Polyester fleece with PTFE membrane (0.2~0.5μ )

#### ④ Control Unit

- AC –Pneumatic Control (Plastic Case)
  - Running time adjustable (0.1~30s)
  - Discharge time adjustable (0.1~30s)
  - Delay period adjustable (0.1~30s)

##### AC2- Pneumatic Control

- Running time adjustable (0.1~30s)
- Discharge time adjustable (0.1~30s)

##### AC3–Pneumatic Control (Stainless Steel Case))

- Running time adjustable (0.1~30s)
- Discharge time adjustable (0.1~30s)
- Delay period adjustable (0.1~30s)
- IP65 (Box Protection Grade)

##### EC - Electric Control

- Running time adjustable
- Discharge time adjustable
- Auto / Manual mode
- Level control available

#### ② Filtration Area

- No mark - Standard
- L - Extra large

#### ⑤ Blowing

- B –Blowing Gear attached
- No mark – Not attached

#### ⑥ Injection valve

- A - Attached
- No mark – Not attached

#### ⑦ Mounting Option

- M –Flange Mount
- No mark – Not attached

#### ⑧ Material

- No mark – Standard(SUS304)
- 316L – SUS316L

## Specification

MODEL	Power Requirement (Pr)	Filter Surface (m <sup>2</sup> )	Max. Conveying Capacity (ton/h)	Capacity ton/h at Different Conveying distance				Rec. Material Pipe Dimension (mm)	Rec. Material Volume (l/cycle)	Weight (Kg)
				8M	13M	23M	33M			
VTC200	5 ~ 10	0.12	1.5	1.5	1.1	0.72	0.48	42 / 51	4	24
VTC200L	5 ~ 10	0.2	1.5	1.5	1.1	0.72	0.48	42 / 51	4	

Remark) 1. Above data based on actual test result of sugar which is specific gravity 0.85 in vertical 3m with 2 bends  
 2. The data can be changed according to the condition such as supply air flow, air pressure and condition of pipe line (bending) when conveyor is operating.

## Dimension

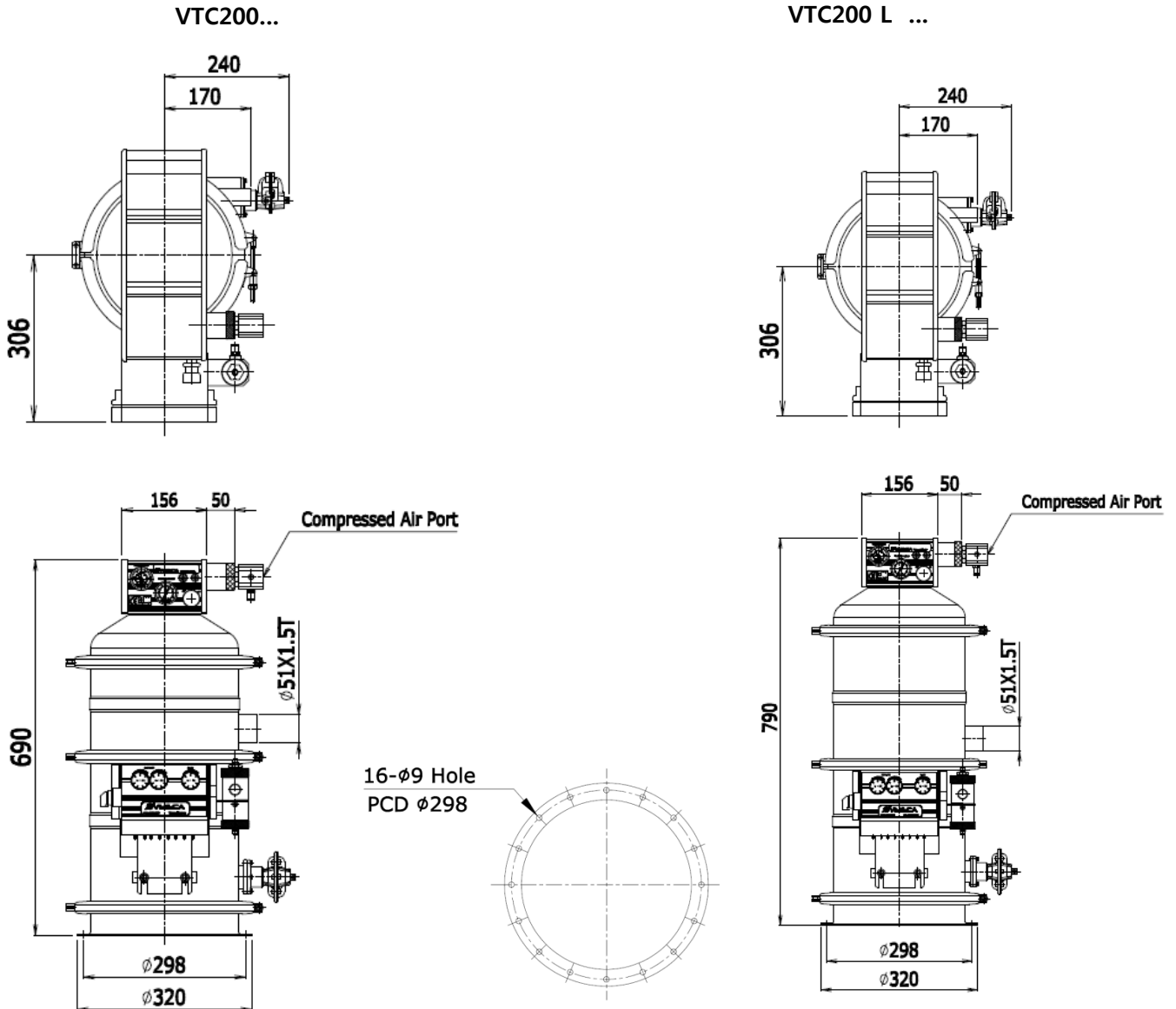

## Series VTC 400 ..

Supply air pressure : 4 ~ 6 bar (Max 7bar)  
(58 ~ 87 psi, Max 101.5 psi)

Air consumption : 1120 ~ 1600 NI/min  
(39.5 ~ 56.5 scfm)

Noise level : 68 ~ 76 dBA

Steel Material : SUS304 / SUS316L

Sealing Material : Silicone

Filter Material : Electrically conductive polyester  
with PTFE membrane



### Ordering information

✓ Please contact VMECA for ATEX approval conveyor.

VTC 400 L - C2 - AC B A - M - 316L  
 ① ② ③ ④ ⑤ ⑥ ⑦ ⑧

#### ① Vacuum Pump

- 400 : Vacuum Pump with Free flow exhaust duct (standard)
- 400 CP : Vacuum Pump with Concentration exhaust port

#### ③ Filter

- B : Bag Filter – Filtering capacity (5μ)
- B1 : Bag Filter – Filtering capacity (0.5μ )
- C2 : Cartridge Filter – Polyester fleece with PTFE membrane (0.2~0.5μ )

#### ④ Control Unit

- AC –Pneumatic Control (Plastic Case)
  - Running time adjustable (0.1~30s)
  - Discharge time adjustable (0.1~30s)
  - Delay period adjustable (0.1~30s)

##### AC2- Pneumatic Control

- Running time adjustable (0.1~30s)
- Discharge time adjustable (0.1~30s)

##### AC3–Pneumatic Control (Stainless Steel Case))

- Running time adjustable (0.1~30s)
- Discharge time adjustable (0.1~30s)
- Delay period adjustable (0.1~30s)
- IP65 (Box Protection Grade)

##### EC - Electric Control

- Running time adjustable
- Discharge time adjustable
- Auto / Manual mode
- Level control available

#### ② Filtration Area

- No mark - Standard
- L - Extra large

#### ⑤ Blowing

- B –Blowing Gear attached
- No mark – Not attached

#### ⑥ Injection valve

- A - Attached
- No mark – Not attached

#### ⑦ Mounting Option

- M –Flange Mount
- No mark – Not attached

#### ⑧ Material

- No mark – Standard(SUS304)
- 316L – SUS316L



## Specification

MODEL	Power Requirement (Pr)	Filter Surface (m <sup>2</sup> )	Max. Conveying Capacity (ton/h)	Capacity ton/h at Different Conveying distance				Rec. Material Pipe Dimension (mm)	Rec. Material Volume (l/cycle)	Weight (Kg)
				8M	13M	23M	33M			
VTC400	10 ~ 20	0.2	2.2	2.2	1.4	0.9	0.5	42 / 51	4	24
VTC400L	10 ~ 20	0.29	2.2	2.2	1.4	0.9	0.5	42 / 51	4	

Remark) 1. Above data based on actual test result of sugar which is specific gravity 0.85 in vertical 3m with 2 bends  
 2. The data can be changed according to the condition such as supply air flow, air pressure and condition of pipe line (bending) when conveyor is operating.

## Dimension

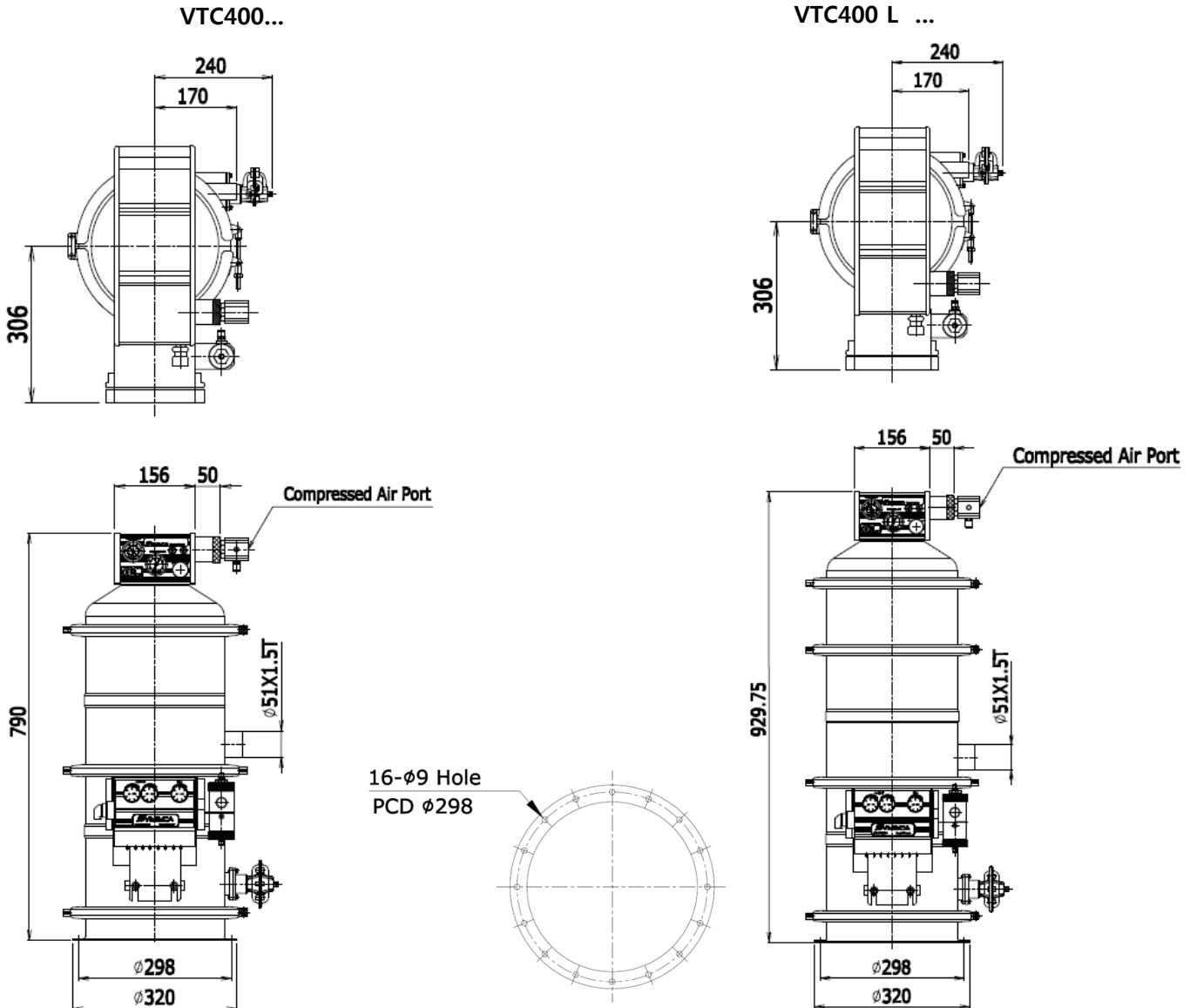

## Series VTC 600 ..

Supply air pressure : 4 ~ 6 bar (Max 7bar)  
(58 ~ 87 psi, Max 101.5 psi)

Air consumption : 1800 ~ 2520 NI/min  
(63.56 ~ 89 scfm)

Noise level : 68 ~ 76 dBA

Steel Material : SUS304 / SUS316L

Sealing Material : Silicone

Filter Material : Electrically conductive polyester  
with PTFE membrane



### Ordering information

✓ Please contact VMECA for ATEX approval conveyor.

VTC 600 L - C2 - AC B A - M - 316L  
 ① ② ③ ④ ⑤ ⑥ ⑦ ⑧

#### ① Vacuum Pump

- 600 : Vacuum Pump with Free flow exhaust duct (standard)
- 600 CP : Vacuum Pump with Concentration exhaust port

#### ③ Filter

- B : Bag Filter – Filtering capacity (5μ)
- B1 : Bag Filter – Filtering capacity (0.5μ )
- C2 : Cartridge Filter – Polyester fleece with PTFE membrane (0.2~0.5μ )

#### ④ Control Unit

- AC –Pneumatic Control (Plastic Case)
  - Running time adjustable (0.1~30s)
  - Discharge time adjustable (0.1~30s)
  - Delay period adjustable (0.1~30s)

##### AC2- Pneumatic Control

- Running time adjustable (0.1~30s)
- Discharge time adjustable (0.1~30s)

##### AC3–Pneumatic Control (Stainless Steel Case))

- Running time adjustable (0.1~30s)
- Discharge time adjustable (0.1~30s)
- Delay period adjustable (0.1~30s)
- IP65 (Box Protection Grade)

##### EC - Electric Control

- Running time adjustable
- Discharge time adjustable
- Auto / Manual mode
- Level control available

#### ② Filtration Area

No mark - Standard

L - Extra large

#### ⑤ Blowing

B –Blowing Gear attached

No mark – Not attached

#### ⑥ Injection valve

A - Attached

No mark – Not attached

#### ⑦ Mounting Option

M –Flange Mount

No mark – Not attached

#### ⑧ Material

No mark – Standard(SUS304)

316L – SUS316L

## Specification

MODEL	Power Requirement (Pr)	Filter Surface (m <sup>2</sup> )	Max. Conveying Capacity (ton/h)	Capacity ton/h at Different Conveying distance				Rec. Material Pipe Dimension (mm)	Rec. Material Volume (l/cycle)	Weight (Kg)
				8M	13M	23M	33M			
VTC600	15 ~ 25	0.2X4	4.0	4.0	2.0	1	0.6	74/101	18	44
VTC600L	15 ~ 25	0.46X4	4.0	4.0	2.0	1	0.6	74/101	18	57

Remark) 1. Above data based on actual test result of sugar which is specific gravity 0.85 in vertical 3m with 2 bends  
 2. The data can be changed according to the condition such as supply air flow, air pressure and condition of pipe line (bending) when conveyor is operating.

## Dimension

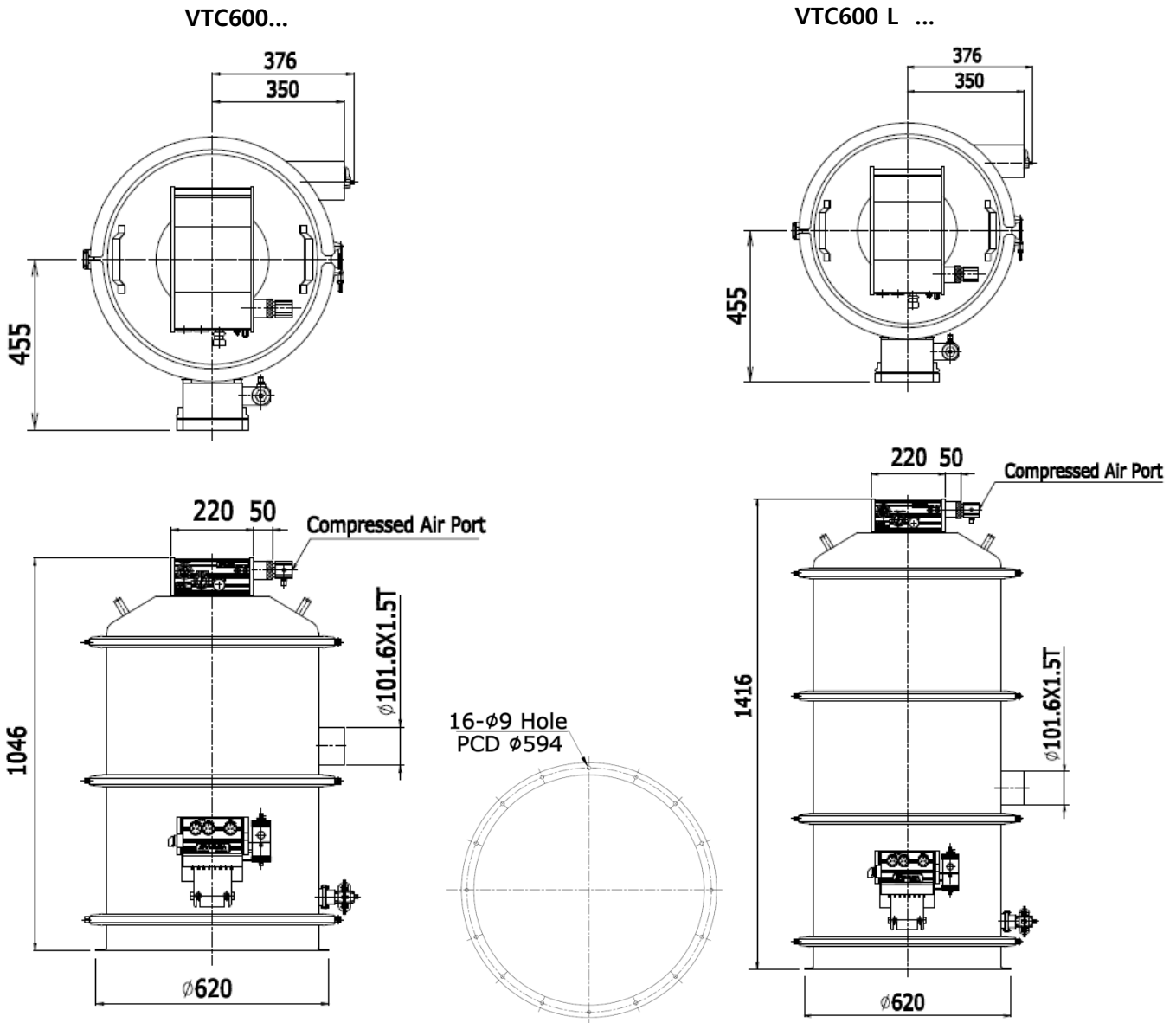

## Series VTC 800 ..

Supply air pressure : 4 ~ 6 bar (Max 7bar)  
(58 ~ 87 psi, Max 101.5 psi)

Air consumption : 2400 ~ 3360 NI/min  
(84.75 ~ 118.65 scfm)

Noise level : 68 ~ 76 dBA

Steel Material : SUS304 / SUS316L

Sealing Material : Silicone

Filter Material : Electrically conductive polyester  
with PTFE membrane



### Ordering information

✓ Please contact VMECA for ATEX approval conveyor.

VTC 800 L - C2 - AC B A - M - 316L  
 ① ② ③ ④ ⑤ ⑥ ⑦ ⑧

#### ① Vacuum Pump

- 800 : Vacuum Pump with Free flow exhaust duct (standard)
- 800 CP : Vacuum Pump with Concentration exhaust port

#### ③ Filter

- B : Bag Filter – Filtering capacity (5μ)
- B1 : Bag Filter – Filtering capacity (0.5μ )
- C2 : Cartridge Filter – Polyester fleece with PTFE membrane (0.2~0.5μ )

#### ④ Control Unit

- AC –Pneumatic Control (Plastic Case)
  - Running time adjustable (0.1~30s)
  - Discharge time adjustable (0.1~30s)
  - Delay period adjustable (0.1~30s)

##### AC2- Pneumatic Control

- Running time adjustable (0.1~30s)
- Discharge time adjustable (0.1~30s)

##### AC3–Pneumatic Control (Stainless Steel Case))

- Running time adjustable (0.1~30s)
- Discharge time adjustable (0.1~30s)
- Delay period adjustable (0.1~30s)
- IP65 (Box Protection Grade)

##### EC - Electric Control

- Running time adjustable
- Discharge time adjustable
- Auto / Manual mode
- Level control available

#### ② Filtration Area

- No mark - Standard
- L - Extra large

#### ⑤ Blowing

- B –Blowing Gear attached
- No mark – Not attached

#### ⑥ Injection valve

- A - Attached
- No mark – Not attached

#### ⑦ Mounting Option

- M –Flange Mount
- No mark – Not attached

#### ⑧ Material

- No mark – Standard(SUS304)
- 316L – SUS316L

## Specification

MODEL	Power Requirement (Pr)	Filter Surface (m <sup>2</sup> )	Max. Conveying Capacity (ton/h)	Capacity ton/h at Different Conveying distance				Rec. Material Pipe Dimension (mm)	Rec. Material Volume (l/cycle)	Weight (Kg)
				8M	13M	23M	33M			
VTC800	20 ~ 40	0.2X4	5.5	5.5	2.8	1.4	1.0	74/101	18	45
VTC800L	20 ~ 40	0.46X4	5.5	5.5	2.8	1.4	1.0	74/101	18	58

Remark) 1. Above data based on actual test result of sugar which is specific gravity 0.85 in vertical 3m with 2 bends  
 2. The data can be changed according to the condition such as supply air flow, air pressure and condition of pipe line (bending) when conveyor is operating.

## Dimension

VTC800...

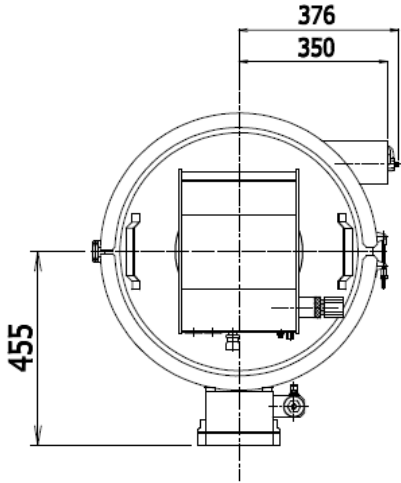

VTC800 L ...

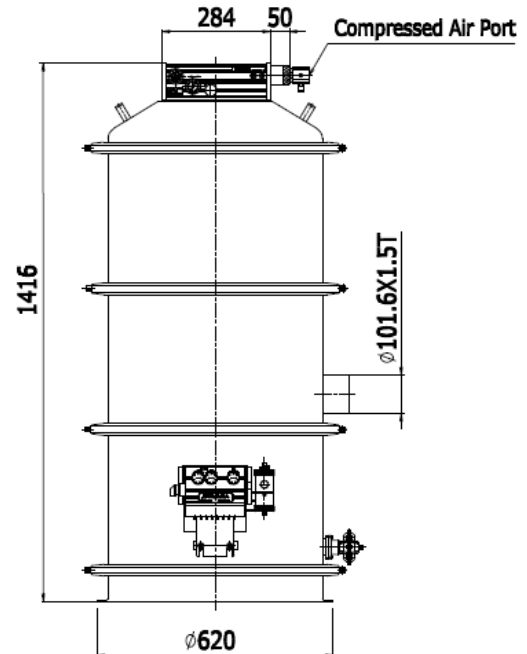
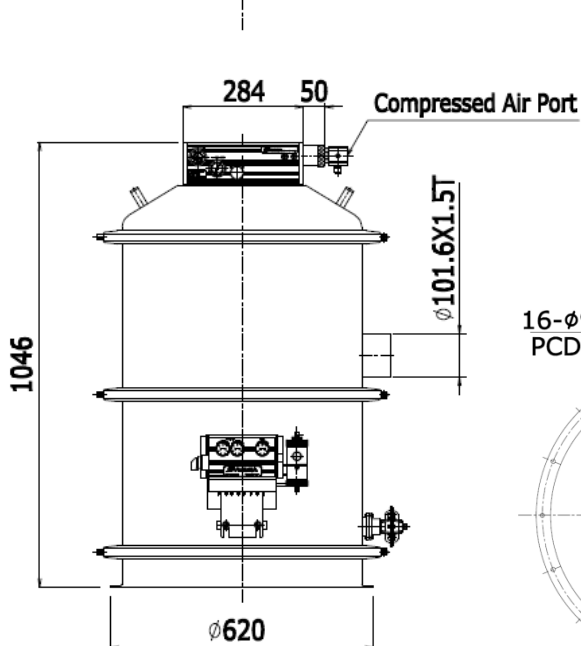
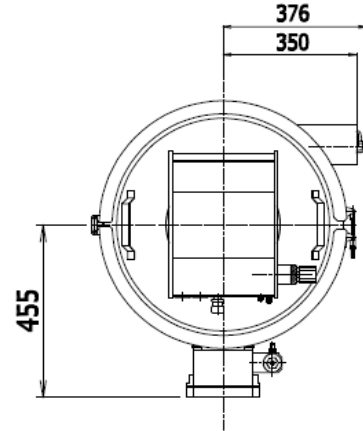

## Series VTC 1000 ..

Supply air pressure : 4 ~ 6 bar (Max 7bar)  
(58 ~ 87 psi, Max 101.5 psi)

Air consumption : 3000 ~ 4140 NI/min  
(105.94 ~ 146.2 scfm)

Noise level : 68 ~ 76 dBA

Steel Material : SUS304 / SUS316L

Sealing Material : Silicone

Filter Material : Electrically conductive polyester  
with PTFE membrane



### Ordering information

✓ Please contact VMECA for ATEX approval conveyor.

VTC 1000 L - C2 - AC B A - M - 316L  
 ① ② ③ ④ ⑤ ⑥ ⑦ ⑧

#### ① Vacuum Pump

- 1000 : Vacuum Pump with Free flow exhaust duct (standard)
- 1000 CP : Vacuum Pump with Concentration exhaust port

#### ③ Filter

- B : Bag Filter – Filtering capacity (5μ)
- B1 : Bag Filter – Filtering capacity (0.5μ )
- C2 : Cartridge Filter – Polyester fleece with PTFE membrane (0.2~0.5μ )

#### ④ Control Unit

- AC –Pneumatic Control (Plastic Case)
  - Running time adjustable (0.1~30s)
  - Discharge time adjustable (0.1~30s)
  - Delay period adjustable (0.1~30s)

##### AC2- Pneumatic Control

- Running time adjustable (0.1~30s)
- Discharge time adjustable (0.1~30s)

##### AC3–Pneumatic Control (Stainless Steel Case))

- Running time adjustable (0.1~30s)
- Discharge time adjustable (0.1~30s)
- Delay period adjustable (0.1~30s)
- IP65 (Box Protection Grade)

##### EC - Electric Control

- Running time adjustable
- Discharge time adjustable
- Auto / Manual mode
- Level control available

#### ② Filtration Area

- No mark - Standard
- L - Extra large

#### ⑤ Blowing

- B –Blowing Gear attached
- No mark – Not attached

#### ⑥ Injection valve

- A - Attached
- No mark – Not attached

#### ⑦ Mounting Option

- M –Flange Mount
- No mark – Not attached

#### ⑧ Material

- No mark – Standard(SUS304)
- 316L – SUS316L

## Specification

MODEL	Power Requirement (Pr)	Filter Surface (m <sup>2</sup> )	Max. Conveying Capacity (ton/h)	Capacity ton/h at Different Conveying distance				Rec. Material Pipe Dimension (mm)	Rec. Material Volume (l/cycle)	Weight (Kg)
				8M	13M	23M	33M			
VTC1000	25 ~ 50	0.46X4	7.0	7.0	3.7	1.8	1.2	74/101	18	48
VTC1000L	25 ~ 50	0.75X4	7.0	7.0	3.7	1.8	1.2	74/101	18	61

Remark) 1. Above data based on actual test result of sugar which is specific gravity 0.85 in vertical 3m with 2 bends  
 2. The data can be changed according to the condition such as supply air flow, air pressure and condition of pipe line (bending) when conveyor is operating.

## Dimension

VTC1000...

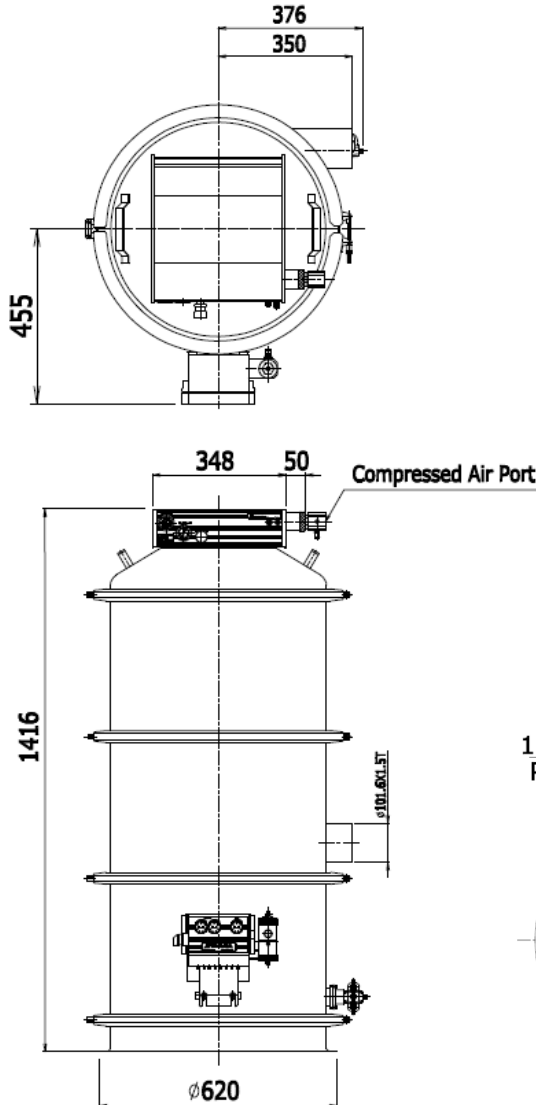

VTC1000 L ...

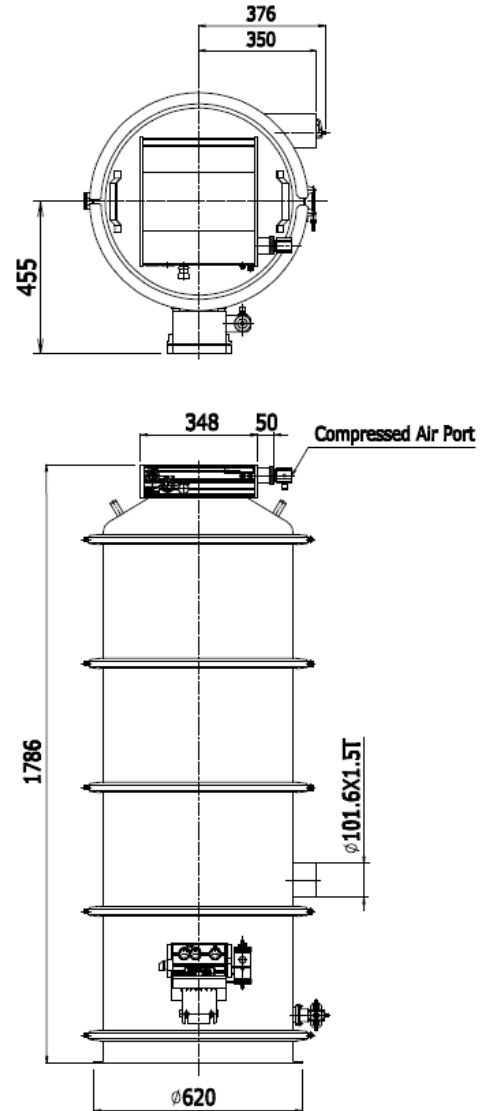

## Series VTC 1200 ..

Supply air pressure : 4 ~ 6 bar (Max 7bar)  
(58 ~ 87 psi, Max 101.5 psi)

Air consumption : 3600 ~ 4920 NI/min  
(127.13 ~ 173.74 scfm)

Noise level : 68 ~ 76 dBA

Steel Material : SUS304 / SUS316L

Sealing Material : Silicone

Filter Material : Electrically conductive polyester  
with PTFE membrane



### Ordering information

✓ Please contact VMECA for ATEX approval conveyor.

VTC 1200 L - C2 - AC B A - M - 316L  
 ① ② ③ ④ ⑤ ⑥ ⑦ ⑧

#### ① Vacuum Pump

- 1200 : Vacuum Pump with Free flow exhaust duct (standard)
- 1200 CP : Vacuum Pump with Concentration exhaust port

#### ③ Filter

- B : Bag Filter – Filtering capacity (5μ)
- B1 : Bag Filter – Filtering capacity (0.5μ )
- C2 : Cartridge Filter – Polyester fleece with PTFE membrane (0.2~0.5μ )

#### ④ Control Unit

- AC –Pneumatic Control (Plastic Case)
  - Running time adjustable (0.1~30s)
  - Discharge time adjustable (0.1~30s)
  - Delay period adjustable (0.1~30s)

##### AC2- Pneumatic Control

- Running time adjustable (0.1~30s)
- Discharge time adjustable (0.1~30s)

##### AC3–Pneumatic Control (Stainless Steel Case))

- Running time adjustable (0.1~30s)
- Discharge time adjustable (0.1~30s)
- Delay period adjustable (0.1~30s)
- IP65 (Box Protection Grade)

##### EC - Electric Control

- Running time adjustable
- Discharge time adjustable
- Auto / Manual mode
- Level control available

#### ② Filtration Area

- No mark - Standard
- L - Extra large

#### ⑤ Blowing

- B –Blowing Gear attached
- No mark – Not attached

#### ⑥ Injection valve

- A - Attached
- No mark – Not attached

#### ⑦ Mounting Option

- M –Flange Mount
- No mark – Not attached

#### ⑧ Material

- No mark – Standard(SUS304)
- 316L – SUS316L



## Specification

MODEL	Power Requirement (Pr)	Filter Surface (m <sup>2</sup> )	Max. Conveying Capacity (ton/h)	Capacity ton/h at Different Conveying distance				Rec. Material Pipe Dimension (mm)	Rec. Material Volume (l/cycle)	Weight (Kg)
				8M	13M	23M	33M			
VTC1200	30 ~ 60	0.46X4	8.5	8.5	4.3	2.1	1.5	74/101	18	50
VTC1200L	30 ~ 60	0.75X4	8.5	8.5	4.3	2.1	1.5	74/101	18	63

Remark) 1. Above data based on actual test result of sugar which is specific gravity 0.85 in vertical 3m with 2 bends  
 2. The data can be changed according to the condition such as supply air flow, air pressure and condition of pipe line (bending) when conveyor is operating.

## Dimension

VTC1200...

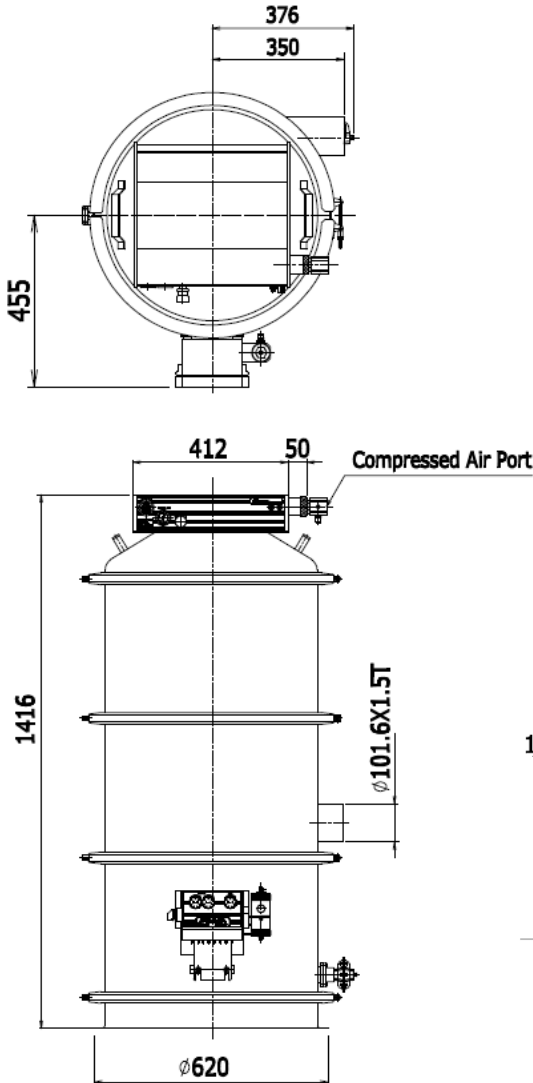

VTC1200 L ...

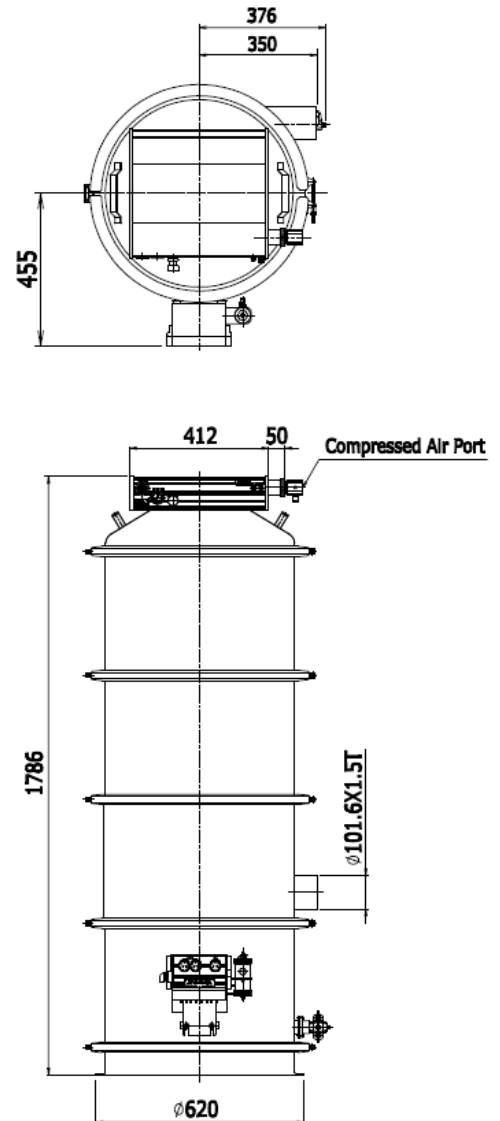

## Accessories

### Vacuum Filters (Cartridge Filter)

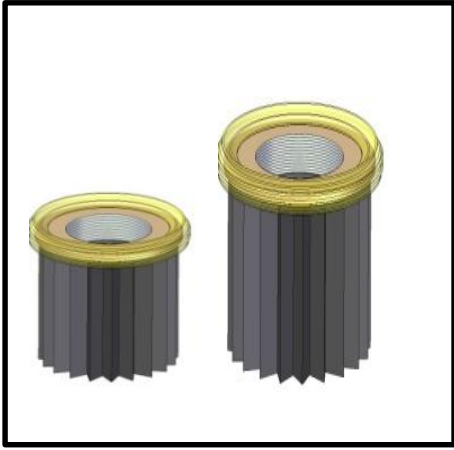

**Material** : Electrically Conductive Polyester with PTFE membrane  
**Temperature, Max** : 70°C  
**Min particle size** : 0.2 ~ 0.5 μm  
**Filter Seal** : Silicon  
**Food quality size** : ø160XL150 / Ø160XL250 / ø160XL350 / ø160XL550 / ø160XL900



### Bag Filter

**Material** : TFE coated antistatic needle Felt of polyester / carbon fibers  
**Temperature, Max** : 80°C  
**Min particle size** : 0.5 μm / 5 μm  
**Filter Seal** : Silicon  
**Washable** 2 to 4 times in 40°C  
**Food quality Size** : Ø150X L150 / Ø150X L250 / Ø150X L350 / Ø150X L550 / Ø150X L900

### Vacuum Filter



**Material** : PA66, PC, PE  
**Temperature, Max** : 100°C  
**Filter Seal** : NBR  
**Pressure range** : Vacuum only

## Accessories

### Control Unit



#### Pneumatic (AC) (Plastic Case)

- . Running time adjustable (0.1~30S)
- . Discharge time adjustable (0.1~30S)
- . Delay period adjustable (0.1~30S)
- . Material : PC,ABS,AL,BS,NBR



#### Pneumatic (AC2)

- . Running time adjustable (0.1~30S)
- . Discharge time adjustable (0.1~30S)
- . Material : PC,ABS,AL,BS



#### Pneumatic (AC3) (Stainless Steel Case)

- . Running time adjustable (0.1~30S)
- . Discharge time adjustable (0.1~30S)
- . Delay period adjustable (0.1~30S)
- . Material : PC,ABS,AL,BS,NBR



#### Electrical (EC)

- . Running time adjustable
- . Discharge time adjustable
- . Auto / Manual mode
- . Level control
- . Voltage : 220V
- . Material : PC,ABS,AL,BS

Accessories

Pipe Fitting



Material : Silicon, SUS304  
 Working Temp : -40°C ~ +200°C

Dimension

	MODEL	Ø [inch]			Mm [inch]
		D	d	D2	L
	CF 5151	51 [2.007]	-	79 [3.11]	110 [4.33]
	CF 3232	32 [1.257]	-	50 [1.968]	82 [3.228]
	CF 1076	101.7 [4]	76.1 [3]	138 [5.433]	150 [5.9]
	CF 7651	76.1 [3]	51 [2.007]	112.5 [4.43]	130 [5.12]
	CF 5140	51 [2.007]	40 [1.574]	79 [3.11]	110 [4.33]
	CF 4032	40 [1.574]	32 [1.259]	64 [2.519]	98 [3.858]
	CF 3222	32 [1.259]	22 [0.866]	50 [1.968]	82 [3.228]
	CF 513Y	51 [2.007]	-	-	181 [7.125]
	CF 323Y	32 [1.259]	-	-	133 [5.236]

## Accessories

### ■ Feed Nozzle



- Adjustable clearance of suction point
- Material : SUS304 (316L), MC Nylon, Al

## Dimension

MODEL	Ø [inch]			Mm [inch]	
	D1	D2	D3	L1	L2
VCFN 32	32 [1.259]	32 [1.259]	51 [2.007]	940~1.005 [37~39.56]	852 [33.5]
VCFN 40	42.8 [1.685]	42.8 [1.685]	63.5 [2.5]	965~1.035 [38~40.74]	855 [33.6]
VCFN 50	51 [2.007]	42.8 [1.685]	63.5 [2.5]	965~1.035 [38~40.74]	855 [33.6]
VCFN 100	101.6 [4]	76.3 [3.003]	101.6 [4]	1,575~1,665 [62~65.5]	1,290 [50.8]

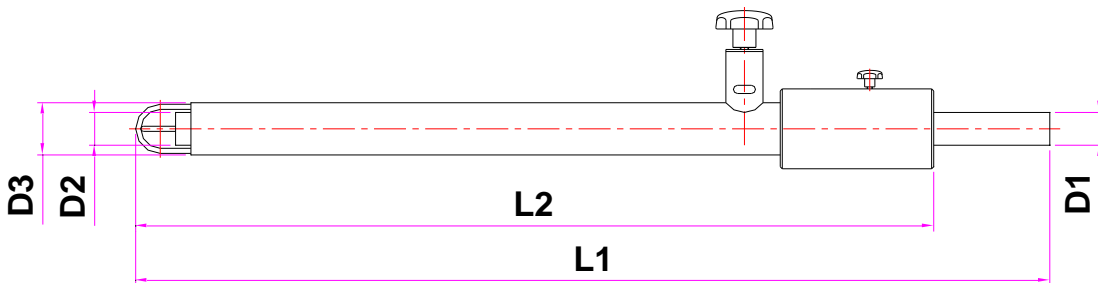

# From Acetylsalicylic acid to Wheat grains

" Some examples of products we have tested successfully"



Acetylsalicylic acid	Chocolate powder	Ginger	Plastic granules
Aluminium oxide	Chromite sand	Grape-sugar	Polyethylene powder
Apple sauce	Cocoa beans	Graphite powder	Potato flour
Apricot stones	Coffee	Gun powder	Powdered blood
Aromic salt	Corn flour	Gypsum	Powdered resin
Baking-powder	Cosmetic powders	Herb tea	PVC powder
Bath salts	Debrisan	Iron oxide	Rice
Beans, wheat	Detergents	Kieselguhr	Rock-salt
Blueberries, frozen	Dextrin	Lactose	Salt
Bone glue	Enamel raw material	Liver salts	Sand
Buckwheat flakes	Expancel	Magnesium oxide	Sawdust
Calcium phosphate	Felspar	Metal flakes	Soya meal
Cane-sugar	Ferrous carbonate	Mica	Spices
Celit	Fertilizer	Milk powder	Sprayed rubber
Cement	Fish food	Mustard seeds	Starch
Chalk	Floating putty	Nickel powder	Sugar
Cheese powder	Fluxing material	Nutmeg	Talcum powder
Chewing gum	Fumaric acid	Peas	Wheat flour
Chicken liver	Gelatine	Penicillin	Wheat grains

## How to select the suitable vacuum conveyor

### The points of considered in choosing a Conveyor System

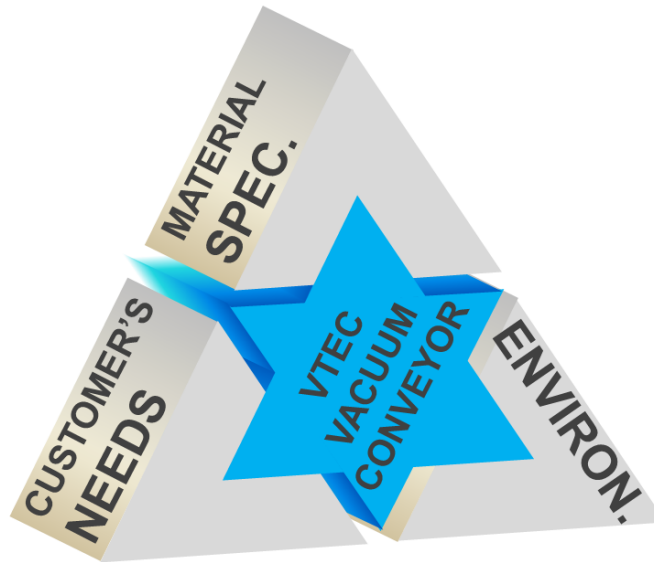

### Let us be the one to assist you on your next project.

When selecting the size of the Conveyor System, you need to take into consideration of the distance\* of which the material needs to travel. \*Distance: the Height plus Width.

You need to know the specifications of the dried material for which will be conveyed. The specification includes fluidity, bulk density, abrasion factor, particle size, moisture sensitivity, explosion hazard, harmfulness, etc.

How you would like to load and unload the dried material into the Conveyor System. If you were going to extract the dried material from a tank or a bag, would you need the use of a feed nozzle? Or would you need an automatic feeder from the storage tank? How would you attach the connection part that does the suction of the dried material to the conveyor? Will the pipe be flexible or fixed in its location of where the dried material will pass?

Transporting materials, as well as additional attributes of environmental conditions by using a vacuum conveyor system will determine the exact specifications. Does the dried material have a good fluidity or not? What is flow-ability of the dried material? Is it free flowing, or bridging? Do you need a Fluidization system for your material? Are the materials sensitive to moisture? Would there be a possibility of the line clogging? Would the materials change characteristics as it is being transported? (In the process of transferring smaller particle materials with friction) Would there be a chance of 2 different materials separating when suction occurs? Are there any precautions to prevent the material being damaged and scratched while the conveyor works?

Explosion may occur during conveying of materials are commonly caused by sparks from static electricity. Prevention methods are available. Does the material have harmful or toxic in any way? How many people are exposed to the product? Can it cause allergic reaction? What filter size would you like? Would the dried materials promote air pollution?

Would your Conveyor System need a central exhaust port? Would you like to recycle the excess material or send it to the outside air? Would the dried materials generate an explosive nature? Are there any things that would restrict the suction and hopper point?

**Let us be the one to assist you on your next project.** We contribute to the efficient operation and profitability of the production process to eliminate any unnecessary risks to make a safer environment. We would like to be the one to satisfy your needs for the vacuum conveyor application. We are always working in order to give you the maximum benefit through our Vacuum Conveyor System.

**Please contact [VTEC/VMECA](#) if you need any further information or consulting for your application.**

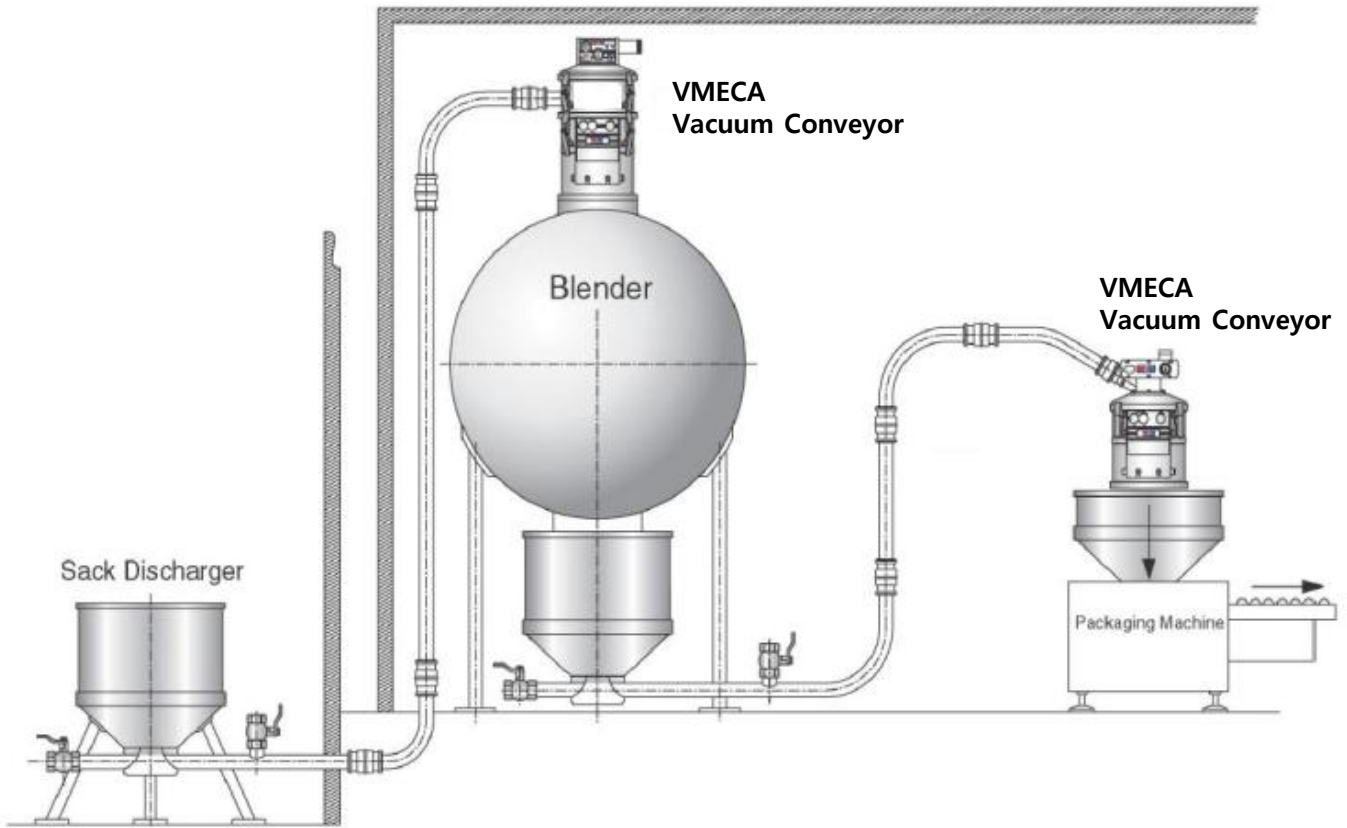

..... VMECA Vacuum Conveying System .....



**GERMANY / VMECA™**

**VMECA GmbH**

Gutenberg Strasse 20  
 D-70794 Filderstadt, Germany  
 Phone: +49-711-4408-3260  
 Fax: +49-711-4408-3261  
 Web: www.vmecca.com  
 Email: vtec@vmecca.com

**ASIA / VMECA™**

**VMECA**

501-5 Doksan-1dong  
 Geumchon-gu Seoul 153817, Korea  
 Tel: +82-2-2617-5008 (Rep.)  
 Fax: +82-2-2617-5009  
 Web : www.vmecca.com  
 Email: vmecca@vmecca.com

**USA / VMECA™**

**VtecUSA Inc.**

1305 San Gabriel Blvd., Suite 203  
 Rosemead, CA 91770  
 Tel: +1-213-258-7114 (Rep.)  
 Fax: +1-626-569-9978  
 Web : www.vmecca.com  
 Email: infousa@vmecca.com

**Distributor**

- Argentina
- Australia
- Austria
- Belgium
- Brazil
- Canada
- China
- Colombia
- Czech
- Denmark
- Egypt
- France
- Hungary
- India
- Indonesia
- Iran
- Israel
- Italy
- Japan
- Lebanon
- Malaysia
- Mexico
- Netherlands
- New Zealand
- Norway
- Philippines
- Poland
- Spain
- Sweden
- Switzerland
- Taiwan
- Thailand
- Turkey
- UK

